

202 SERIES

Vertical Hold Down Clamps | Product Overview

Features:

- Two bar styles available
- Low profile T-Handle version available
- Available in stainless steel
- Accommodates M6 or 1/4" spindle accessories
- BLK models feature a black, non-reflective finish

Applications:

- Checking fixtures
- Assembly & test
- Light machining
- Woodworking

Also Available:

See page MC-ACC-1 for accessories

802-U Pneumatic Toggle Clamp
(See page MC-PTC-3)

202-U/USS
Flanged Base
U-Bar



-**USS** Stainless
Steel Model



202-UL
Flanged Base
Long U-Bar



202/-SS
Flange Base
Solid Bar



-**SS** Stainless
Steel Model



202-UB
Straight Base
U-bar



202-B
Straight Base
Solid Bar



202-TU
Flanged Base
U-bar,
T-Handle



202-T
Flanged Base
Solid Bar
T-Handle



202-U-L ⓘ
Flanged Base
Open U-Bar



202-U-L-BLK ⓘ
Blackout Series
Flanged Base
Open U-Bar



202-UB-L ⓘ
Straight Base
Open U-Bar



202-UB-L-BLK ⓘ
Blackout Series
Straight Base
Open U-Bar



202305
Flanged Grip.
Provides added safety
and protection. Fits all
202 Series (except
T-Handle) clamps.
Order separately.



ⓘ This item is available upon request

Model	Max. Holding Capacity	Clamp Bar Opening (+10°)	Handle Opening (+10°)	Weight	Accessories (Supplied)	
					Spindle Assembly	Flanged Washers
202-U	890 N [200 lbf]	105°	65°	0,16kg [0.35lbs]	202208-M	215105
202-UL	1110 N [250 lbf]				202943-M	215905
202-USS	890 N [200 lbf]			0,15kg [0.33lbs]	202208-M	---
202	1110 N [250 lbf]			205943-M	---	
202-SS	890 N [200 lbf]			0,16kg [0.35lbs]	202208-M	215105
202-UB	0,15kg [0.33lbs]					
202-B	0,17kg [0.38lbs]					
202-TU	890 N [200 lbf]					
202-T	0,16kg [0.35lbs]			---	---	
202-U-L ⓘ						
202-U-L-BLK ⓘ						
202-UB-L ⓘ						
202-UB-L-BLK ⓘ						

ⓘ This item is available upon request

Holding Capacities

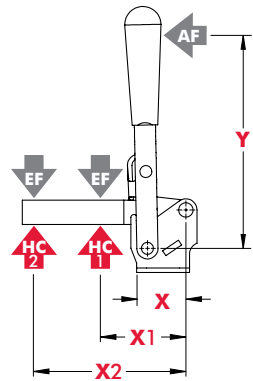

Model	X	X1	X2	Y	±HC1	±HC2	±EF(X1):AF	±EF(X2):AF
202-U			[2.25] 57	[3.42] 87	[200 lbf] 890N	[140 lbf] 625N		5:1
202-UL		[1.25] 32	[2.88] 73			[150 lbf] 670N	10:1	4:1
202-USS			[2.25] 57	[3.00] 76	[250 lbf] 1110N	[170 lbf] 760N		5:1
202			[1.88] 48	[3.42] 87	---	[200 lbf] 890N	---	8:1
202-SS				[3.00] 76	---	[250 lbf] 1110N		
202-UB		[1.25] 32	[2.25] 57	[3.42] 87	[200 lbf] 890N	[140 lbf] 625N	10:1	5:1
202-B	[0.79] 20		[1.88] 48		---	[200 lbf] 890N	---	8:1
202-TU		[1.25] 32	[2.25] 57	[2.13] 54	[200 lbf] 890N	[140 lbf] 625N	11:1	7:1
202-T			[1.88] 48		---	[200 lbf] 890N	---	6:1
202-U-L ⓘ								
202-U-L-BLK ⓘ		[1.25] 32	[2.25] 57	[3.42] 87	[200 lbf] 890N	[140 lbf] 625N	10:1	5:1
202-UB-L ⓘ								
202-UB-L-BLK ⓘ								

Dimensions shown "mm [inch]" ± HC = Holding Capacity, EF = Exerting Force, AF = Applied Force

ⓘ This item is available upon request

202 SERIES

Vertical Hold Down Clamps | Dimensions | -U/-UL/-USS/-SS/-UB/-B/-TU/-T

202-U
Flanged Base
U-Bar

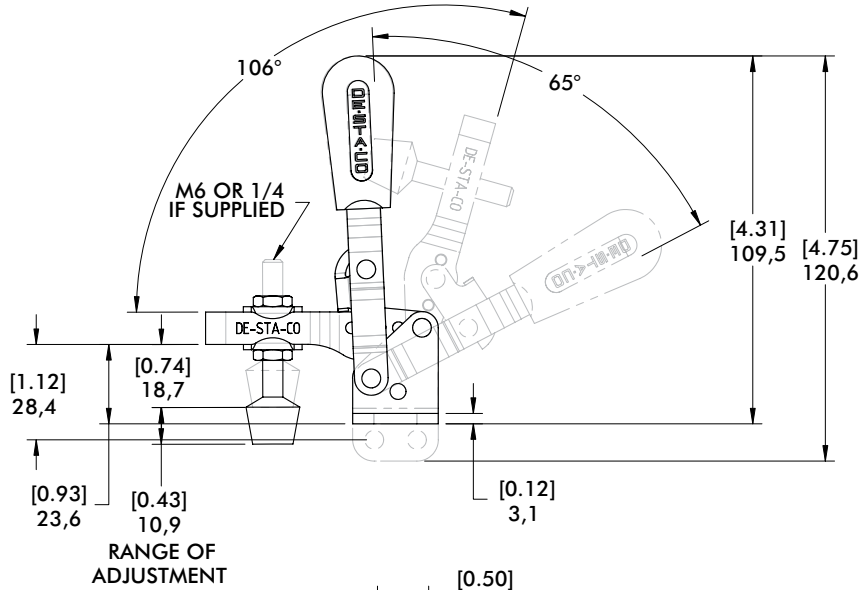
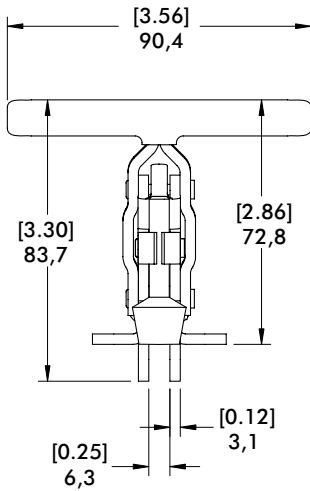
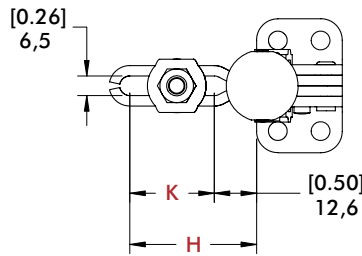

Open Bar Option

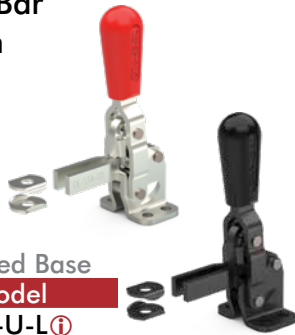

See page
MC-ACC-7
for complete
offering of open
bar accessories

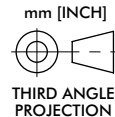
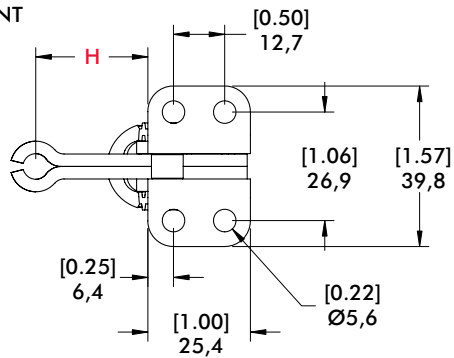

Flanged Base
Model

202-U-L ⓘ
202-U-L-BLK ⓘ

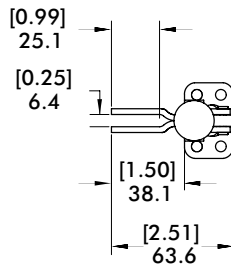

Straight Base
Model

202-UB-L ⓘ
202-UB-L-BLK ⓘ

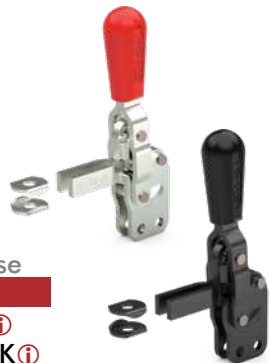

Bar Style	Clamp Models	H	K
	202-U/202-UB/ 202-USS/202-TU	[1.73] 44,1	[0.98] 25
	202-UL ⓘ	[2.29] 58,1	[1.51] 38,4
	202/202-B/ 202-T/202-SS	[1.08] 27,4	---
	202-U-L ⓘ/ 202-UB-L ⓘ	[1.50] 38,1	---

ⓘ This item is available upon request

VERTICAL HOLD DOWN CLAMPS

Application Example

Application Areas

Clamping during the assembling, drilling, testing, gluing, locking of covers and much more. The vertical clamp is the most frequently used product whenever clamping products are to be integrated with a manual fixture.

The essential product features

- In the clamping position, the handle is vertical
- Vertical clamps open at an angle between 75° and 215°
- Vertical clamps are offered with U-shaped or heavy-duty solid clamping bars
- Vertical clamps have a straight or flanged base.
The heavy-duty vertical clamps possess a base that can be welded on without a hole pattern

